

CALIBRES 140.1 and 140.2

HOW TO ASSEMBLE

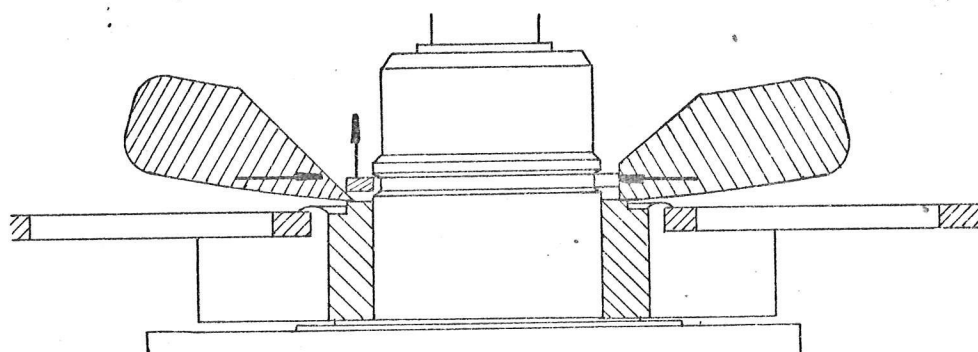

THICK OIL

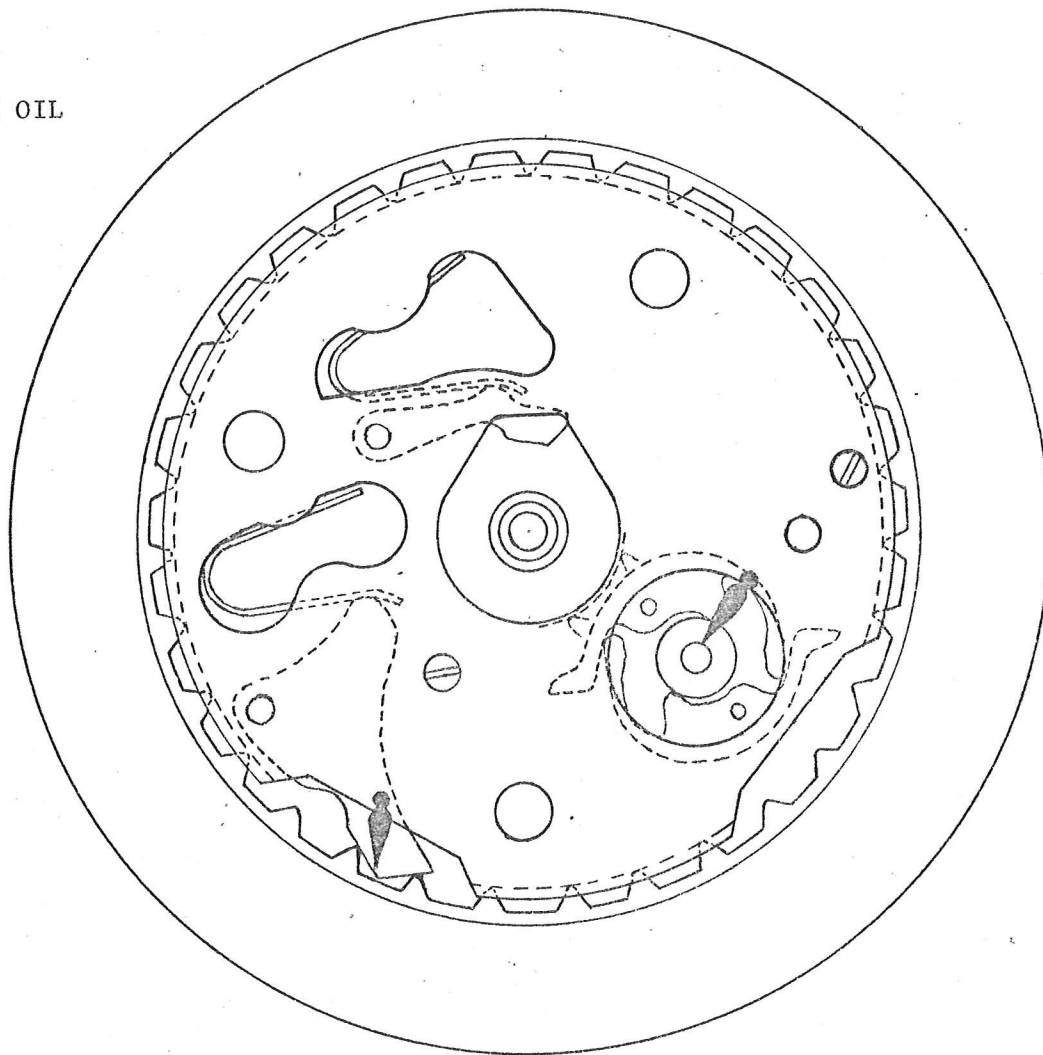

HOW TO ASSEMBLE

- 1) - Oil centre tube before inserting date mechanism.
- 2) - Introduce hour wheel, cylindrical part of centre setting wheel facing peg of driving wheel.
- 3) - Insert date indicator.
- 4) - Insert date jumper-spring and day-of-week jumper spring, if any.
- 5) - Insert driving wheel, taking care to index two teeth of the sector on either side of the cylindrical part of the centre setting wheel.
- 6) - Insert stay-plate of date indicator, and screw down.
- 7) - Check freedom of date indicator.
- 8) - Insert date jumper spring and day-of-week jumper spring, if any.
- 9) - Oil protruding part of date jumper-spring and driving-wheel peg.
- 10) - Insert day disk.
- 11) - Place clip right down on pipe (bush).
- 12) - Check for operation.

N.B. : Stay-plate should not be nickel-plated.

DISASSEMBLY OF CLIP

- 1) - This can be done easily using tweezers 14 B as shown on drawing.
- 2) - Put one tweezer leg facing clip aperture, perform one rotation of movement.

DAY and DATE

CHARACTERISTICS

The Day-and-Date System merely comprises 9 parts and 2 screws.

The driving wheel supports 2 fingers to move forward simultaneously the day and the day disks from 11 hrs to 12 hrs, thus coming close to the instant type leap-change system.

These 2 swing-aside fingers allow high-speed date re-setting by moving the hands back to 11 hrs. The rotating motion of hands, in both directions, between 11 and 12 hrs, is performed without releasing the crown, and the system is the equivalent of a date-corrector device.

Day re-setting is actuated as usual by backward rotation of hands over 24 hours.

Day disks of two sizes can be accommodated in this Calibre :

- reduced  $\emptyset$  for separate apertures and intermediate dial rest
- large  $\emptyset$  for common aperture and external dial rest on bezel flange.

A S S E M B L Y

- Because of the small number of parts, their design and arrangement, assembly will take very little time.
- The date-disk is pre-centered by a recess in the bottom plate.
- The stay-plate covers up all parts ; it is centered by feet.
- The spring of the date jump-lever and that of the day-star jumping lever can be fitted with ease, after the stay-plate has been inserted.
- The day-disk is held in position by a clip, thus rendering the operation of the day indicator (semainier) independent of the dial and hands.



FRANCE EBAUCHES  
6, rue du Muguet - 25 - BESANCON France

Téléphone 80.13.11 +                      Télex 36.100

( 140  
11 1/2 ( 140-1  
( 140-2  
25,600 mm  
Vibrations : 21.600

- 140 : Lever movement - centre seconde - solid banking (fixed banking-pins)  
140-1 : Accelerated date-change - fast date-setting  
140-2 : Accelerated day and date-change - fast date-setting

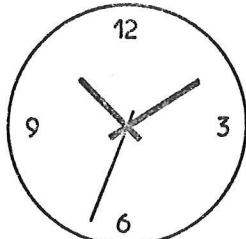

140

curved dial

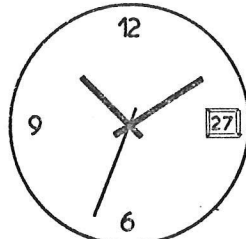

140-1

flat or curved  
dial

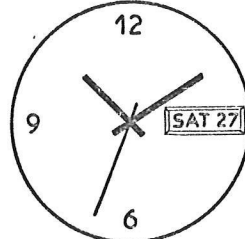

140-2

flat dial with  
single aperture

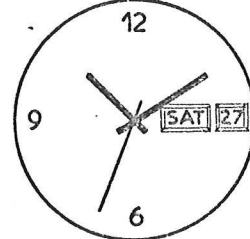

140-2

flat or curved  
dial with  
double aperture

- TECHNICAL CHARACTERISTICS -

(dimensions in mm)

	140	140-1	140-2
<u>FRAME</u>			
Over-all diameter .....	26,000	26,000	26,000
Casing diameter .....	25,600	25,600	25,600
Height of bead .....	1,300	1,810	2,150
Height on bridge .....	4,000	4,510	4,850
Max. height on crown-wheel screw .....	4,030	4,540	4,880
<u>DIAL</u>			
Diameter of the dial-foot holes in the plate .....	1,000	0,800	0,800
<u>HAND FITTING</u>			
Seconds, diameter of the hand pipe .....	0,210	0,210	0,210
Cannon-pinion, diameter of the hand pipe .....	0,900	0,900	0,900
Hours wheel, diameter of the hand pipe .....	1,400	1,400	1,400
<u>HAND FITTING HEIGHTS</u> (above the plate)			
Hours .....	0,950/1,250	0,920/1,250	0,890/1,250
Minutes .....	1,400/1,700	1,370/1,700	1,360/1,700
Seconds .....	1,850/2,150	1,820/2,150	1,820/2,150

LIST OF WATCH-PARTS FOR CALIBRE 140

Reference	List of materials
100	Plate
105	Barrel bridge
110	Train wheel bridge
121/3	Balance cock for stud holder and for shock-absorber device, flat balance-spring
125	Pallet cock
163/1	Centre pipe
172	Stud for the minute wheel spring
182	Barrel and cover (without arbor)
195	Barrel arbor
200/1	Large driving wheel (and pinion) with cannon pinion
201/1	Large driving wheel (and pinion) without cannon pinion
210	Third wheel (and pinion)
227	Sweep second wheel (and pinion)
240	Cannon pinion with clam notch
243	Cannon pinion without clam notch
255	Hour wheel
260	Minute wheel
307	Regulator with adjustable stud holder, for flat balance-spring
401	Winding stem
407	Clutch wheel
410	Winding wheel
415	Ratchet wheel
420	Transmission wheel
422	Transmission wheel ring
425	Click
430	Click spring
435	Yoke (clutch lever)
440	Yoke spring (set spring)
443	Setting lever (detent)
445	Setting lever spring (set bridge)
450	Setting wheel (small hole)
450/1	Setting wheel (large hole)

Reference	List of materials
476	Minute wheel spring
502	Setting lever post
601	Jewel for large driving wheel, upper G 35. 90.25
602	Jewel for large driving wheel, lower G 60.110.35
605	Jewel for third wheel, upper G 16.120.25
3920/605	Combination setting for third wheel, upper 16.120.40
606	Jewel for third wheel, lower G 16.120.25
3920/606	Combination setting for third wheel, lower 16.120.40
610	Jewel for fourth wheel, upper G 16.120.40
3920/615	Combination setting for escape wheel, upper 12.120.40
615	Jewel for escape wheel, upper G 12.120.25
616	Jewel for escape wheel, lower G.12.120.25
3920/616	Combination setting for escape wheel, lower 12.120.40
620	Jewel for pallet staff, upper G 12. 90.22
621	Jewel for pallet staff, lower G 12. 90.22
618	Intermediate roller 82.140.35
702	Escape wheel (and pinion), pivoted, for two end-pieces
705	Escape wheel (and pinion), with straight pivots
710	Jewelled pallet fork and staff
714	Pallet staff
721	Balance with flat balance-spring (regulated)
728	Balance staff for shock-absorbing device
730	Roller
770	Mainspring
5.101	Case screw
5.105	Barrel-bridge screw
5.110	Gear-train bridge screw
5.121	Balance-cock screw
5.125	Pallet cock screw
5.415	Ratchet wheel screw
5.420	Transmission wheel screw
5.425	Click screw
5.445	Screw for setting lever spring
5.738	Balance-spring stud screw
5.750	Dial screw

ADDITIONAL WATCH-PARTS FOR THE DATE-WATCH

CALIBRE 140.1 (Aperture type)

Reference	List of materials
100	Plate
227	Sweep second wheel (and pinion)
243	Cannon pinion without clam notch
2.556	Date indicator driving wheel
2.557/1	Date indicator, transferred
2.558	Double-toothing hour wheel
2.575	Date jumper spring
2.576	Date jumper
2.740	Date mechanism stay-plate
2.900	Jewel for date indicator driving wheel 62 - 120 - 25
52.740	Date mechanism stay-plate screw
450	Setting wheel

ADDITIONAL WATCH-PARTS FOR THE DAY AND DATE WATCH

CALIBRE 140.2 (Aperture type)

Reference	List of materials
100	Plate
145	Dial rest
227	Sweep second wheel (and pinion)
243	Cannon pinion without clam notch
2.556	Date indicator driving wheel
2.557/1	Date indicator, transferred
2.558	Double-toothing hour wheel
2.561/1	Day star with dial disk, single aperture
2.561/2	Day star with dial disk, double aperture
2.573	Day jumper spring
2.575	Date jumper spring
2.576	Date jumper
2.577	Day jumper
2.740/1	Calendar mechanism stay-plate, single aperture
2.740/2	Calendar mechanism stay-plate, double aperture
2.900	Jewel for date indicator driving wheel 62 - 120 - 25
52.740	Calendar mechanism stay-plate screw
450	Setting wheel.
255/1	Security-clip of the day star

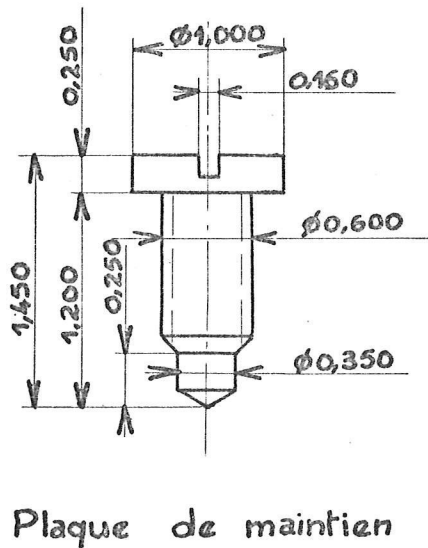
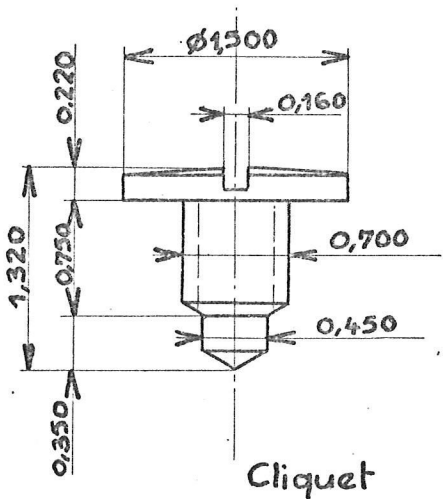
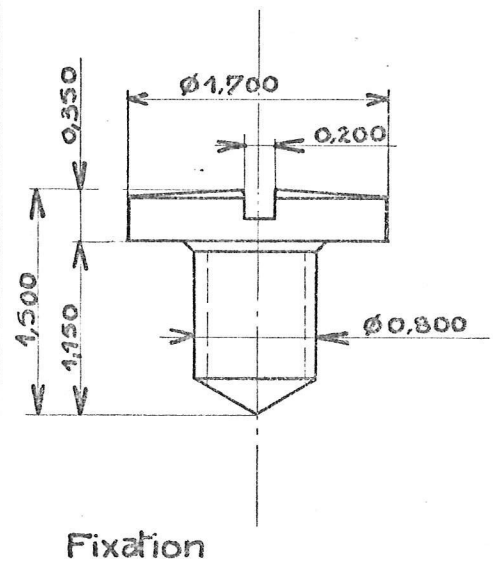
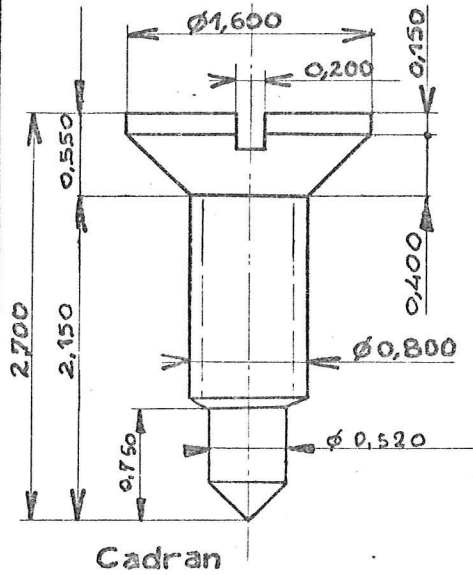
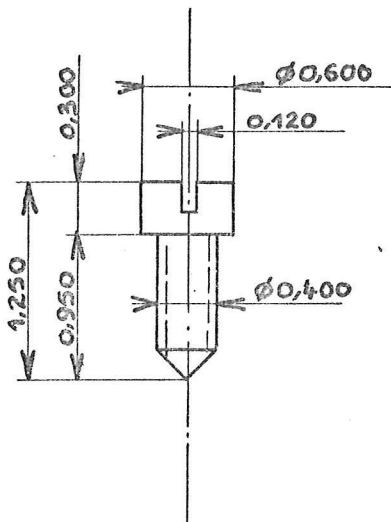
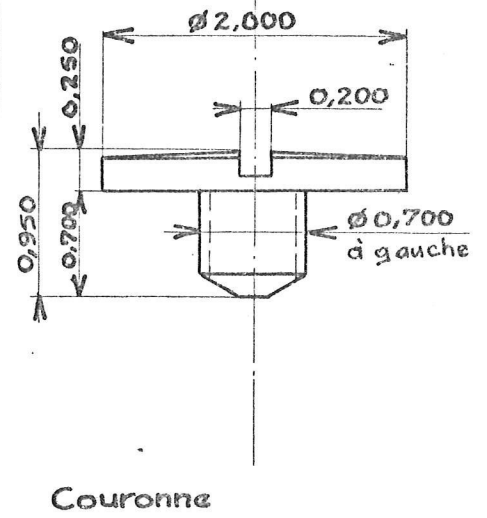
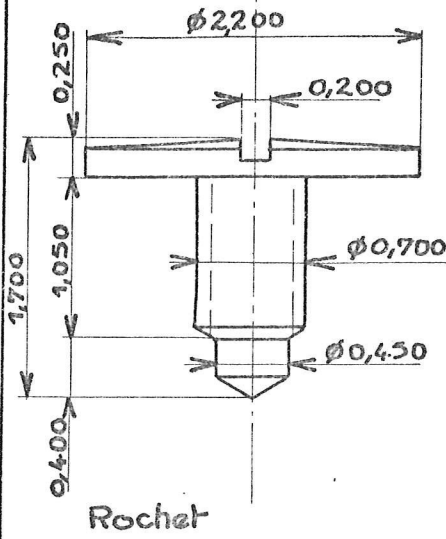
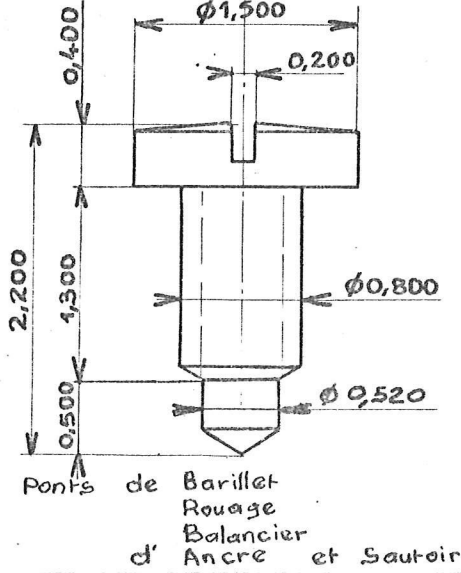

# VIS

FRANCE EBAUCHES  
Centre technique

Matière :

Traitement :

F				Cotes en mm. tolérances en microns
E				Cotes sans tolérance :
D				le :
C	8/5/70	Red dutigeron vis de cadran	4-9-69	par : IM
B	11/3/70	Mod. tête vis fixation. anc. 1,300	échelle :	vis :

CAL 11<sup>1</sup>/<sub>2</sub> 140

140-91

C  
B

Ce document et toutes ses annexes sont la propriété exclusive de la Société FRANCE EBAUCHES. Le dossier qu'ils constituent ayant été confié personnellement au destinataire ne peut, en aucun cas, être copié, ni reproduit sans l'accord écrit d'une personne mandatée spécialement à cet effet par la Société FRANCE EBAUCHES. Il ne doit jamais être communiqué, ni rendu accessible à des tierces personnes.

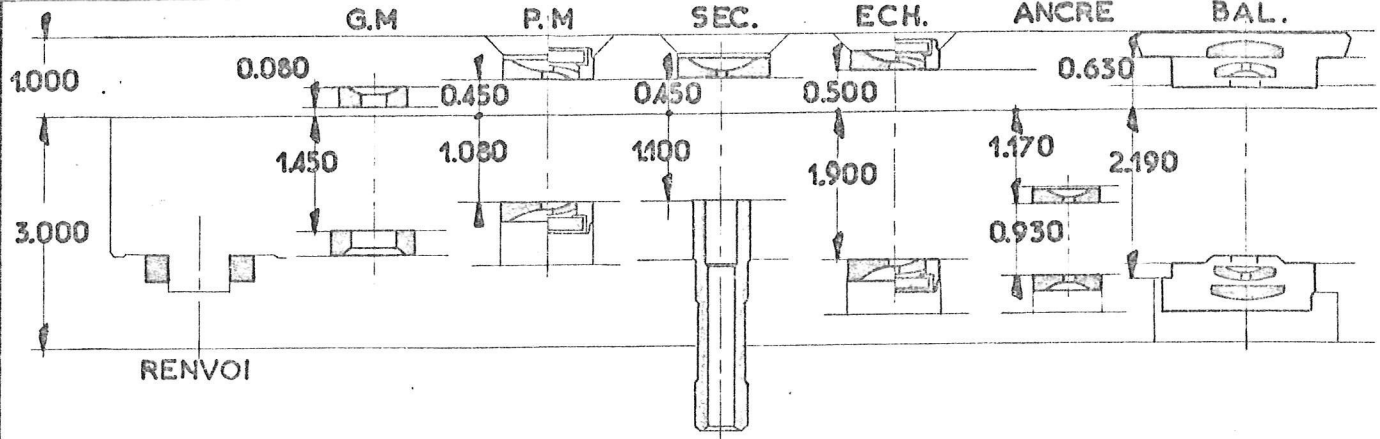

Mobile	Cage				Pierre				Mobile		
	Nbre		profond. posage	épaisseur matière	Genre	∅ trou	∅ total	Epaiss.	Entre portées	Ebat	
Grande Moyenne	17	21	platine	1.45	0.35	G.l.trou 0.25	0.60	1.10	0.35	1.50	0.03
	17	21	pont de rouage	0.08	0.27	G.l.trou 0.16	0.35	0.90	0.25		
Petite	17		platine	1.08	0.87	G	0.16	1.20	0.25	1.50	0.03
	17		pont de rouage	0.45	0.55	G	0.16	1.20	0.25		
Moyenne	21	21	platine	1.08 (+0.21)	0.87	chaton combiné	0.16	1.20	0.40	1.92	0.03
	21	21	pont de rouage	0.45 (+0.21)	0.55	chaton combiné	0.16	1.20	0.40		
	17	21	pont de rouage	0.45	0.55	G	0.16	1.20	0.25		
Seconde			platine	1.10	0.80	tube de centre 0.76 x 3.00			1.52	0.03	
	17	21	pont de rouage	0.45	0.55	G	0.16	1.20			0.25
Echappement	17		platine	1.90	0.77	G	0.12	1.20	0.25	2.37	0.03
	17		pont de rouage	0.50	0.50	G	0.12	1.20	0.25		
	21	21	platine	1.90 (+0.21)	0.77	chaton combiné	0.12	1.20	0.40		
	21	21	pont de rouage	0.50 (+0.21)	0.50	chaton combiné	0.12	1.20	0.40		
Ancre	17	21	platine	(2.10) ass 0,93	0.57	G	0.12	0.90	0.22	0.90	0.03
	17	21	pont d'ancre	0.00	0.24	G	0.12	0.90	0.22		
Balancier	17	21	Pour systèmes				0.10	1.90		2.92	0.03
	17	21	amortisseurs ou chatons				0.10	1.90			
	17	21									
	17	21									
Renvoi			CAL. 140 uniquement				0.82	1.40	0.35		
Roue entraîneuse	17	21	CAL. 140-1.140-2 uniquement				0.615	1.20	0.25		
Nbre Bal. Ech.	3	3	Hauteur platine:			3.00	Hauteur pont d'ancre:		0.24		
	17	21	Hauteur pont de rouage:			1.00	Hauteur pont de balancier:		1.00		

La platine a des pieds-vis côté ponts

En 140-1 et 140-2 (dato et semainier) 4 plots dépassant côté cadran

## EMPIERRAGE CAL 140.11 1/2

FRANCE EBAUCHES

Centre technique

Matière :

Traitement :

F					Cotes en mm. tolérances en microns	
E					Cotes sans tolérance :	
D	23.10.70	Mod. prof. posage ancre sur platine	M3	le :	par :	CAL 11 1/2 140
C	22/5/70	Mod. tableau (Aj. renvoi. Roue entraîneuse) Plan refait	M3	22 / 5 / 70	22	

D  
C

17 Rubis

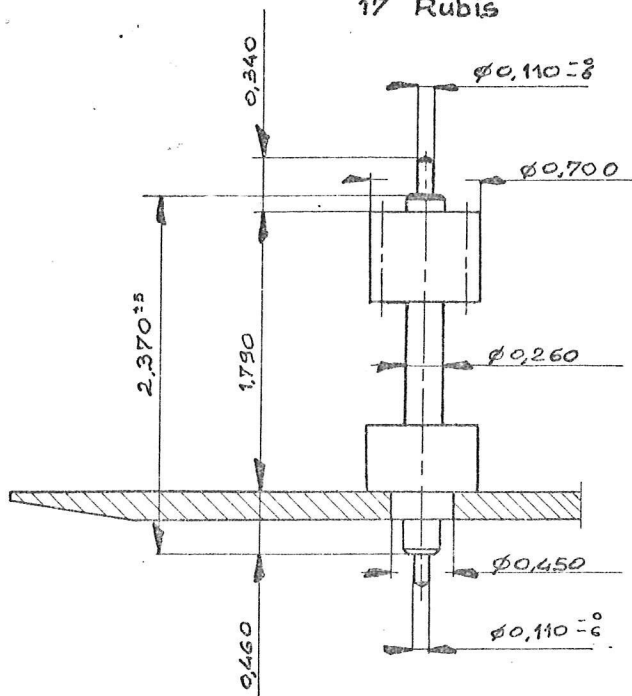

21 Rubis

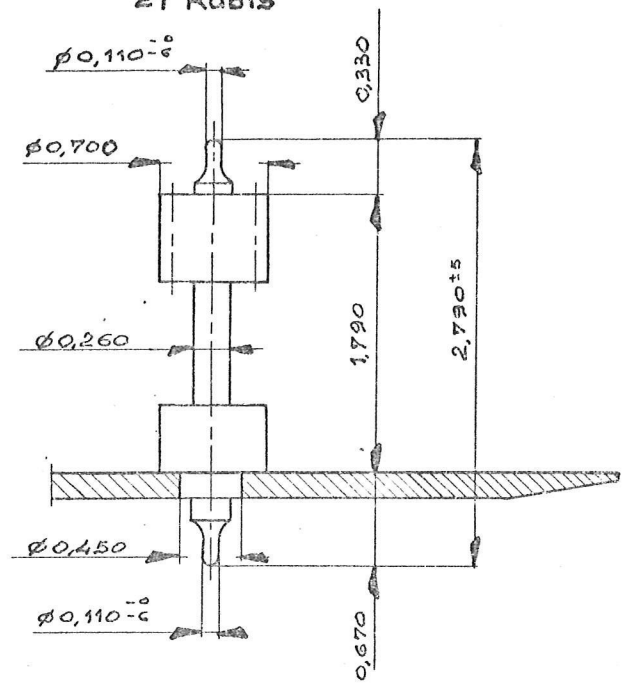

$\phi$  roue d'échappement 5,350

Tige d'ancre

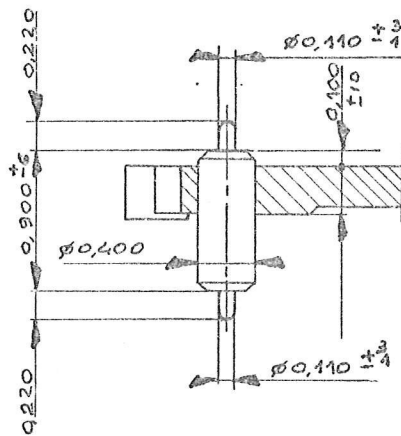

Nota: Assortiment N° 8

Distances 3,050 - 3,400

Axe de balancier

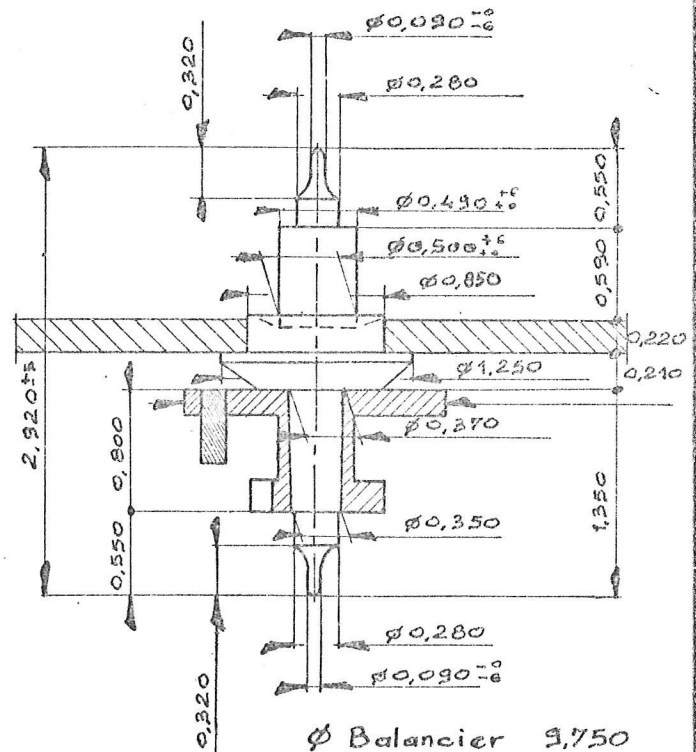

$\phi$  Balancier 3,750  
I 14 mg.cm<sup>2</sup>

ASSORTIMENT CAL 140.11 1/2

FRANCE EBAUCHES  
Centre technique

Matière :

Traitement :

F	24.6.74	Mod. tol. entrepartes anc = 2 ; Sécantité Ajouté 110
E	24.3.74	Mod $\phi$ ajustement balancier $\phi 0,900 \rightarrow \phi 0,950$
D	15/1/74	des. $\phi$ boîlle pipera échappement avec 0,700 $\phi$ ajustement vis de 0,500 cylindrique.

MB	Cotes en mm. tolérances en microns	
c.c	Cotes sans tolérance :	
MS	le :	par :
	13/8/63	LM

CAL 11 1/2 140

	échelle :	visa :
	20M	5-

140-03

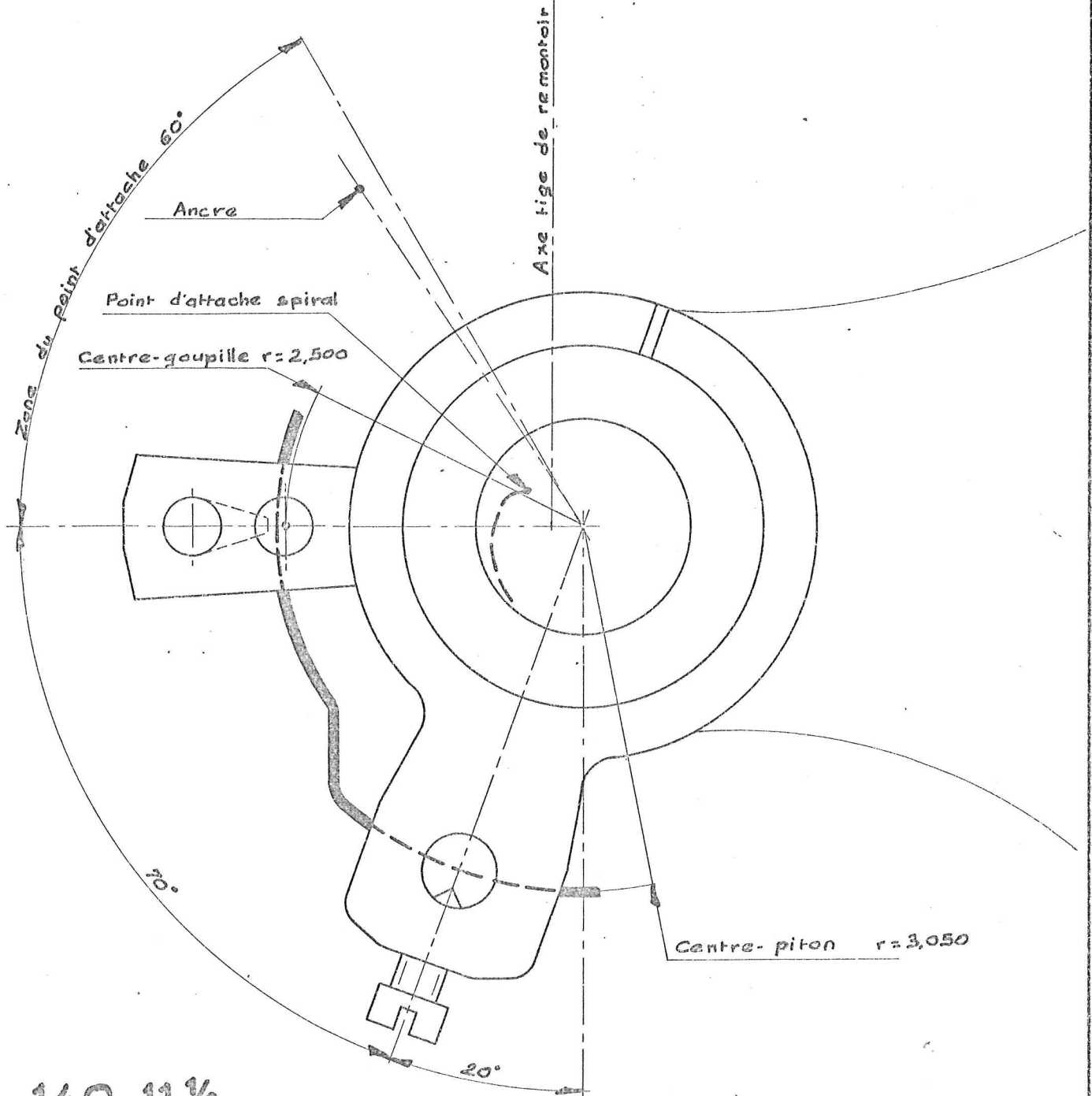
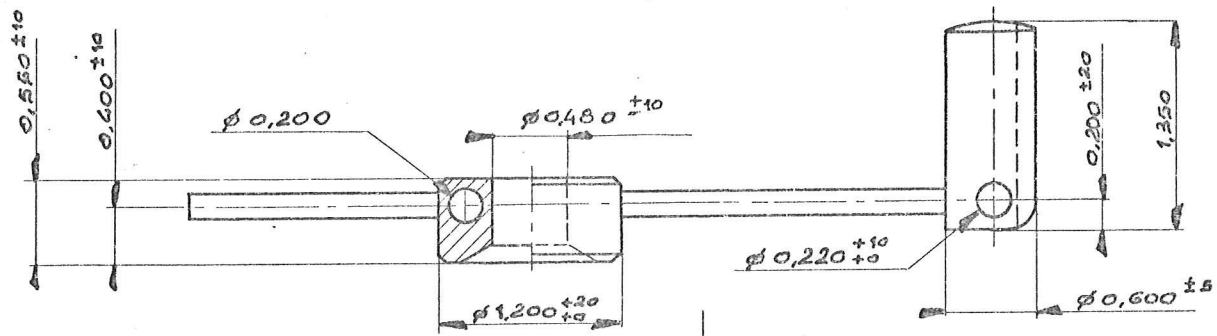

CAL 140 11½

POINT D'ATTACHE DU SPIRAL

RAQUETTE COURTE

FRANCE EBAUGHES

Centre technique

F			
E			
D			
C			
B			

Cotes en mm. tolérances en microns

Cotes sans tolérance :

le :  
12/8/69

par :  
LM

échelle :

visa :

CAL 11½ 140

140-05

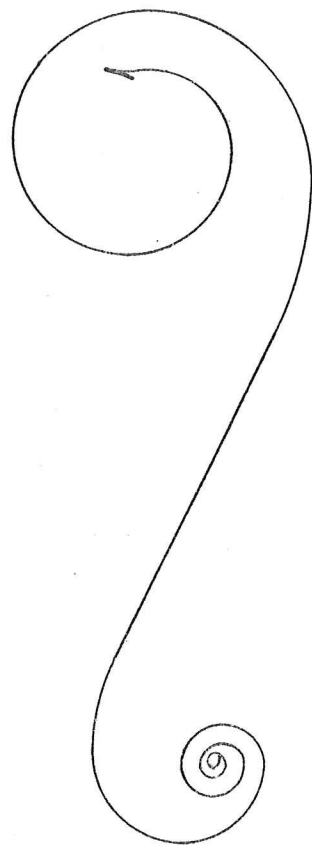

Echelle 1

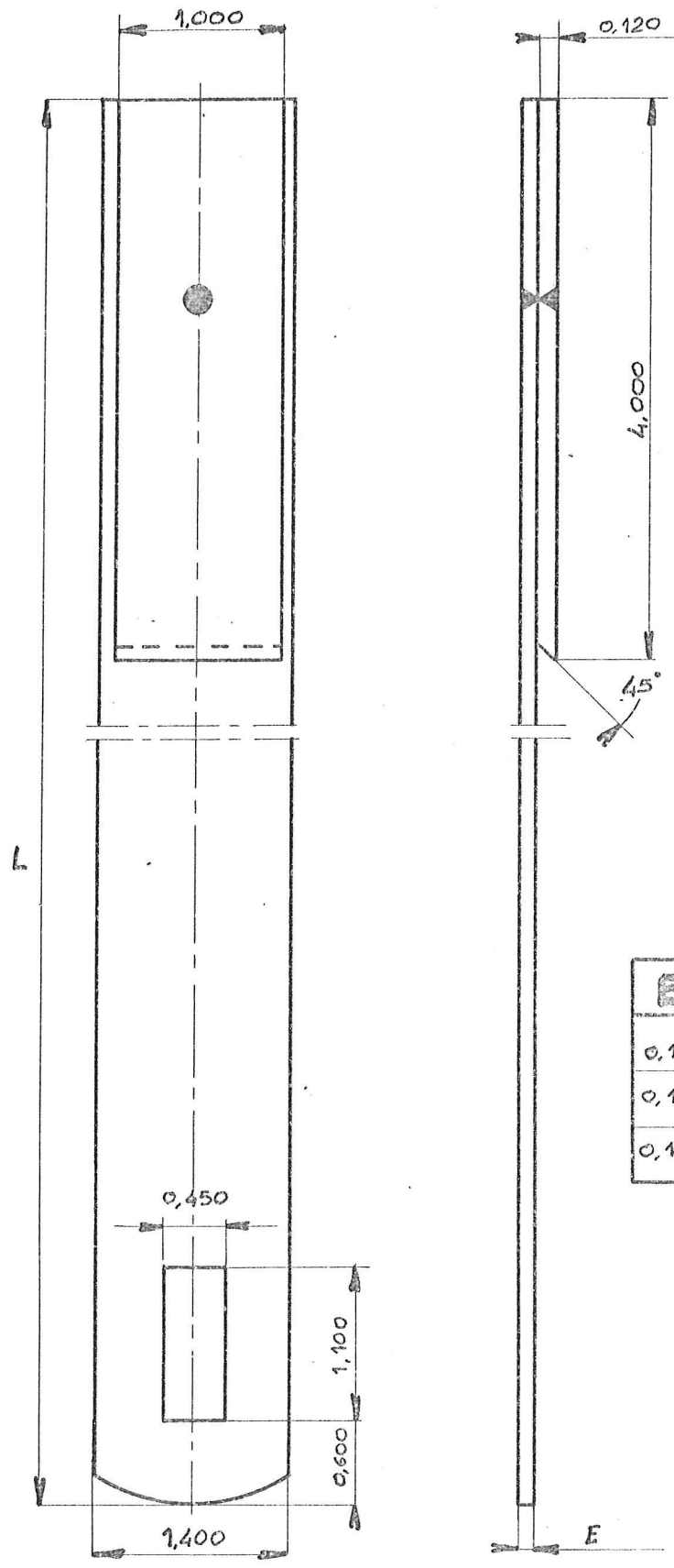

E	L
0,1125	355
0,1150	345
0,1175	335

CAL 140.11 1/2

RESSORT DE BARILLET

FRANCE EBAUCHES  
Centre technique

Matière : ..... Traitement : .....

F			
E			
D			
C			
B			

Cotes en mm. tolérances en microns	
Cotes sans tolérance :	
le : 27/5/69	par : HM
échelle :	visa :

CAL 11 1/2 140

140-07

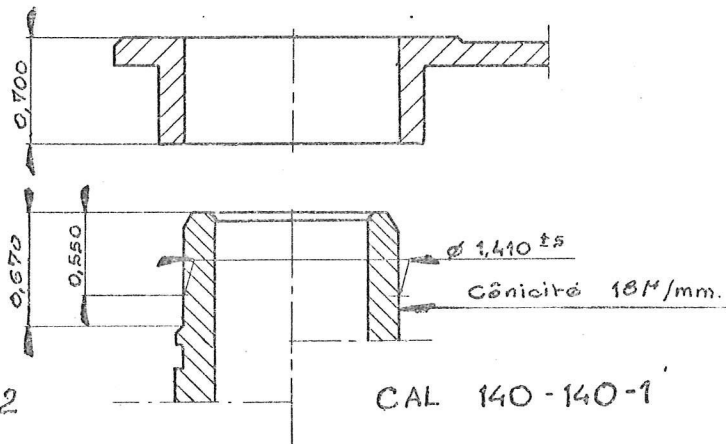
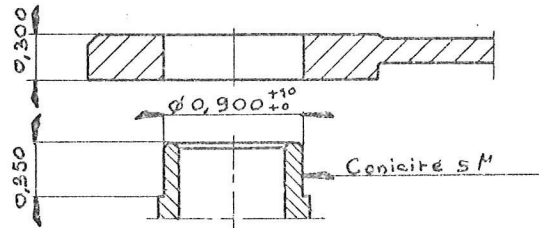
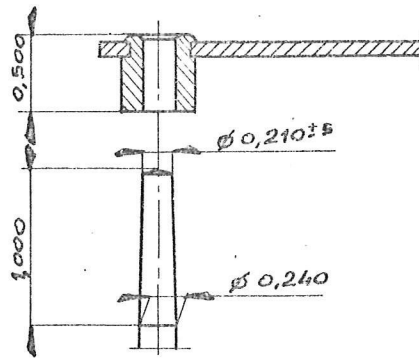

CAL 140-2

CAL 140-140-1

CAL 140.11 1/2

AIGUILLAGE

FRANCE EBAUCHES

Centre technique

Matière :

Trattement :

F			
E			
D			
C			
B			

Cotes en mm. tolérances en microns

Cotes sans tolérance :

le :  
9/9/69

par :  
HM

échelle :

visa :

CAL 11 1/2 140

140-09

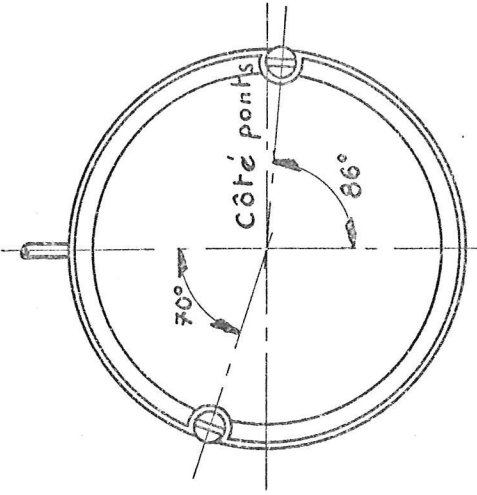

Position des vis de fixation

Déplacement de l'aiguillage depuis le platine	1,850
Hauteur totale de la cage avec aiguillage	5,850

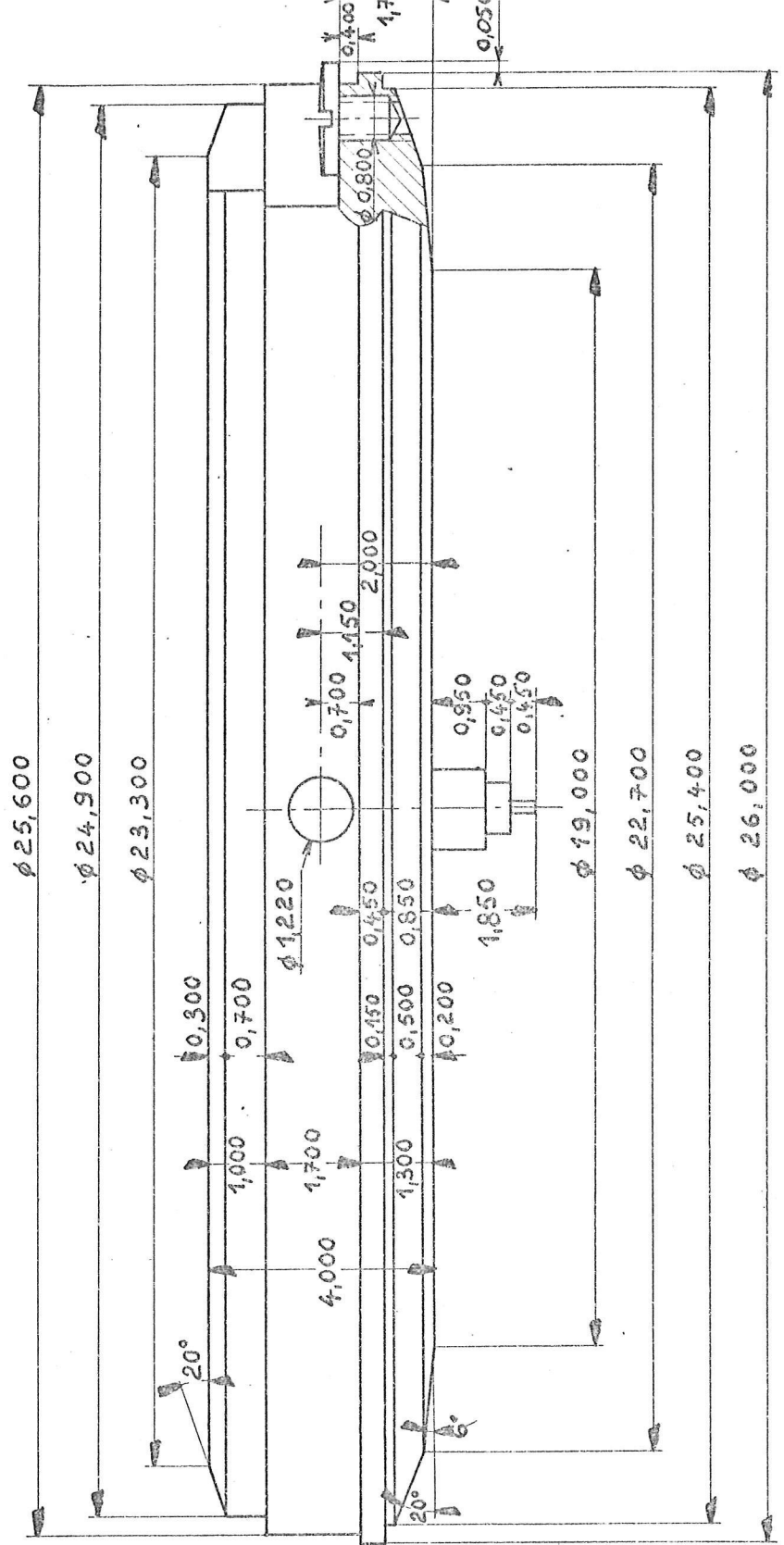

CAL 140.11 1/2

CAGE POUR BOITE

FRANCE EBAUCHES

Centre technique

Matière :

Traitement :

F  
E  
D  
C  
B

Cotes en mm. tolérances en microns

Cotes sans tolérance :

le :  
8/7/63

par :  
HM

échelle :

visa :

CAL 11 1/2 140

110-11

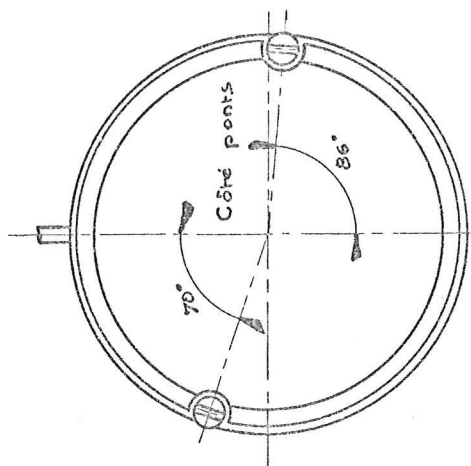

Position des vis de fixation

Déplacement de l'aiguille depuis la platine	1,820
Hauteur totale de la cage avec l'aiguillage	6,330

∅ 25,600

∅ 24,500

∅ 23,300

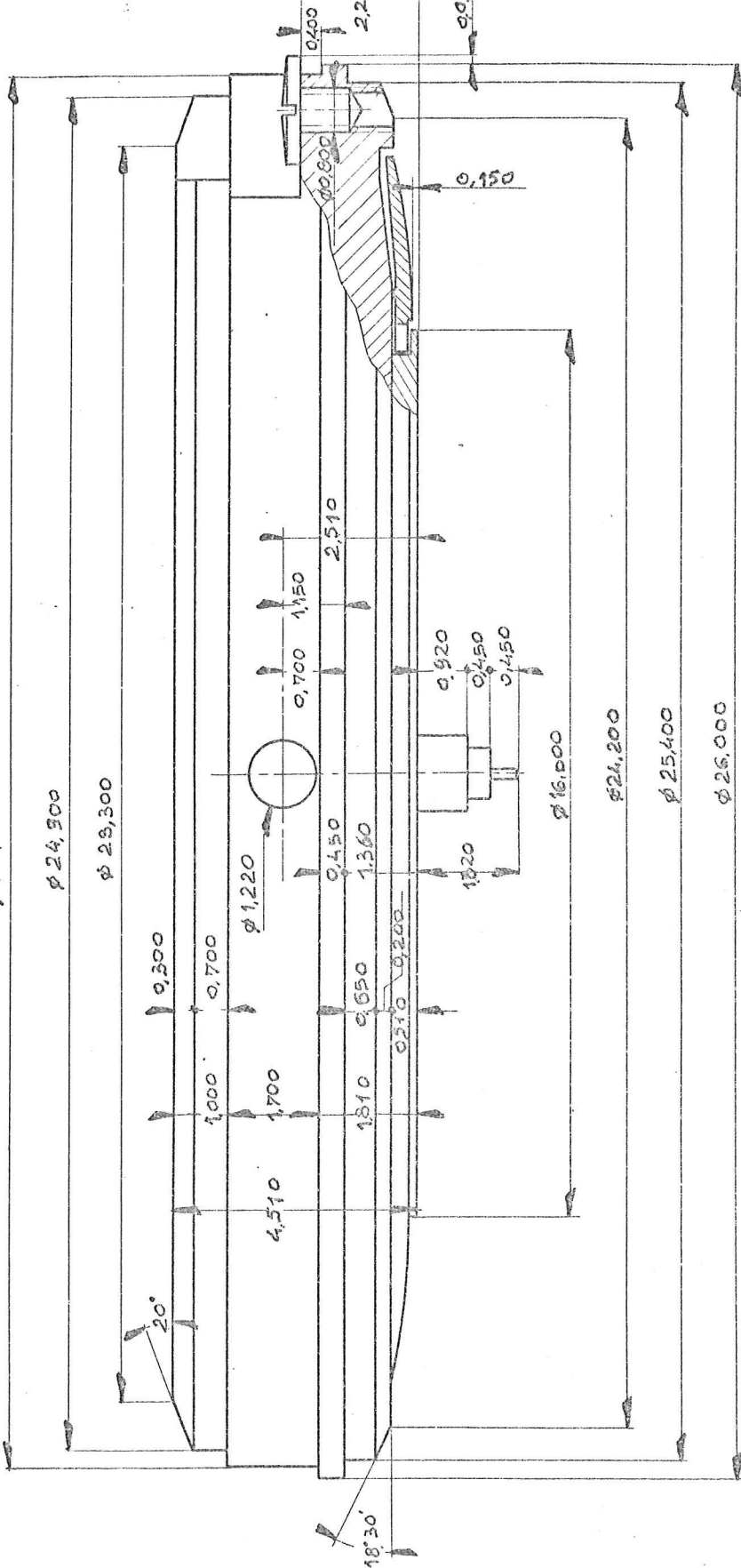

CAL 140-1 11 1/2

CAGE POUR BOITE

FRANCE EBAUCHES

Centre technique

Matière : .....

Traitement : .....

F	
E	
D	
C	
B	9-7-70 Modification de cotes.

Cotes en mm. tolérances en microns

Cotes sans tolérance :

le :

8/7/69

par :

HM

échelle :

visa :

CAL 11 1/2 140-1

140-1-2

B

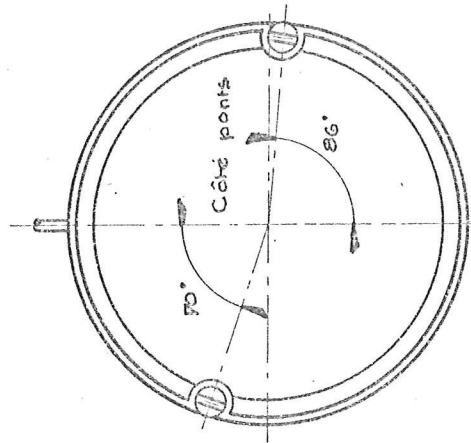

Position des vis de fixation

Déplacement de l'aiguillage depuis la platine	1,810
Hauteur totale de la cage avec l'aiguillage	6,660

∅ 25,600

∅ 24,900

∅ 23,300

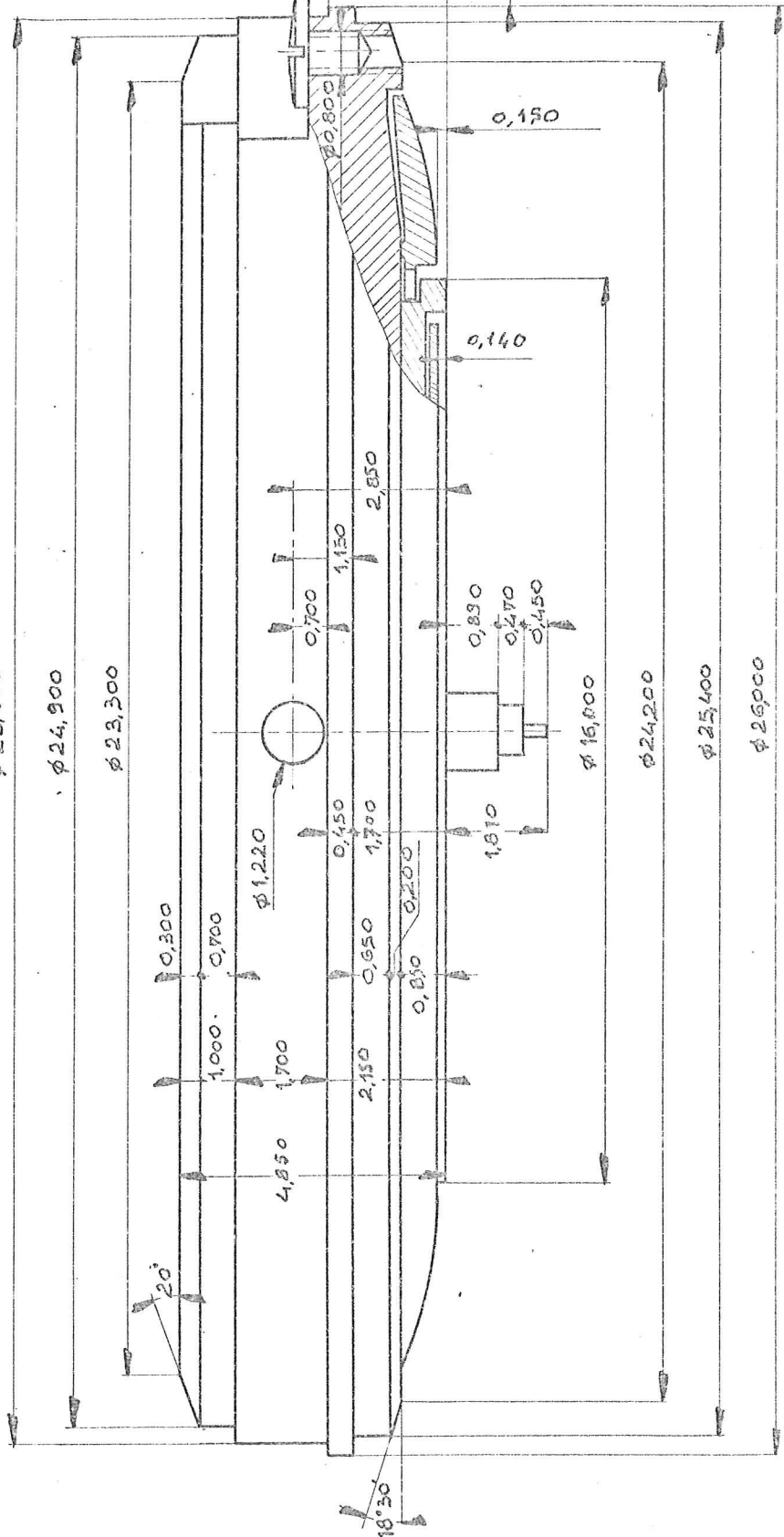

CAL 140-2 11 1/2

CAGE POUR BOITE Cadran galbé

FRANCE EDAUCHES  
Centre technique

Matière : .....

Traitement : .....

F		
E		
D		
C		
B	3.7.70	Modification de cotes

Cotes en mm. tolérances en microns

Cotes sans tolérance :

le :  
8/7/69

par :  
LM

échelle :

via :

CAL 11 1/2 140-2

140-2-13

B

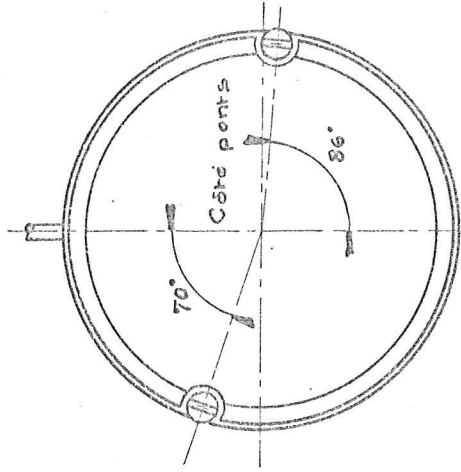

Position des vis de fixation

Déplacement de l'aiguillage depuis la platine	1,810
Hauteur totale de la cage avec l'aiguillage	6,660

∅ 25,600

∅ 24,900

∅ 23,300

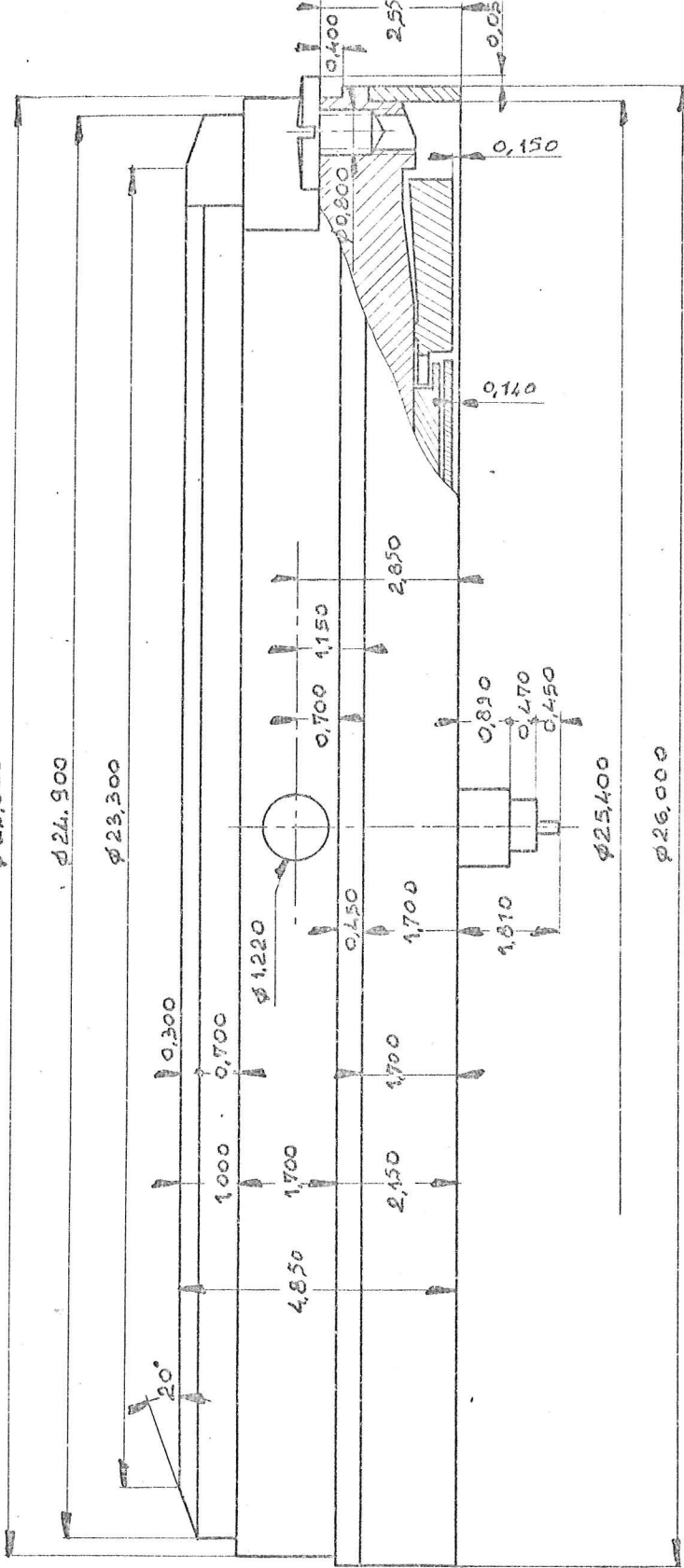

CAL 140-2 11 1/2

CAGE POUR BOITE

Cadron plat

FRANCE EBAUCHES

Centre technique

Matière :

Traitement :

F		
E		
D		
C		
B	9.7.70	Modification de cotes

Cotes en mm. tolérances en microns

Cotes sans tolérance :

le :  
8/7/69

par :  
LM

échelle :

visa :

CAL 11 1/2 140-2

11021

B

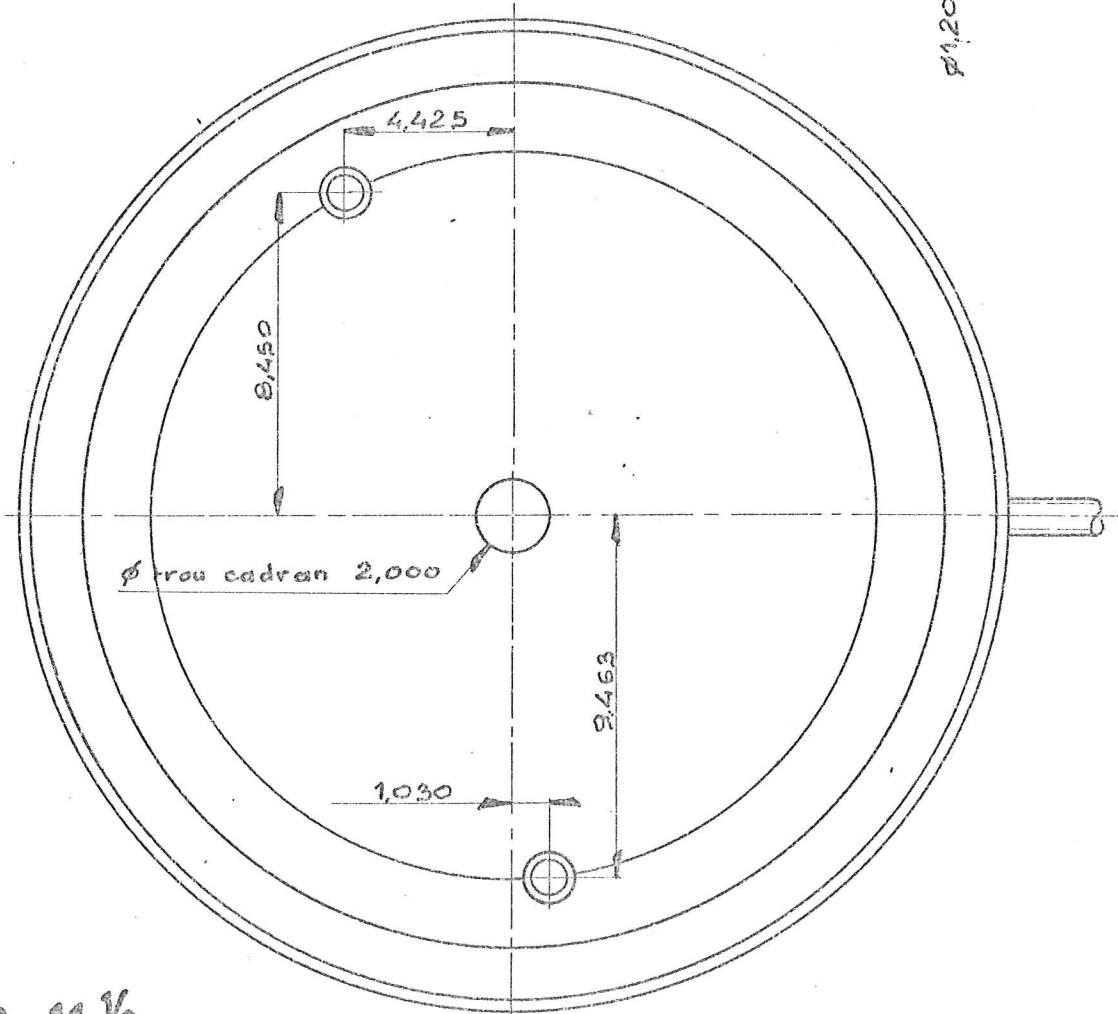
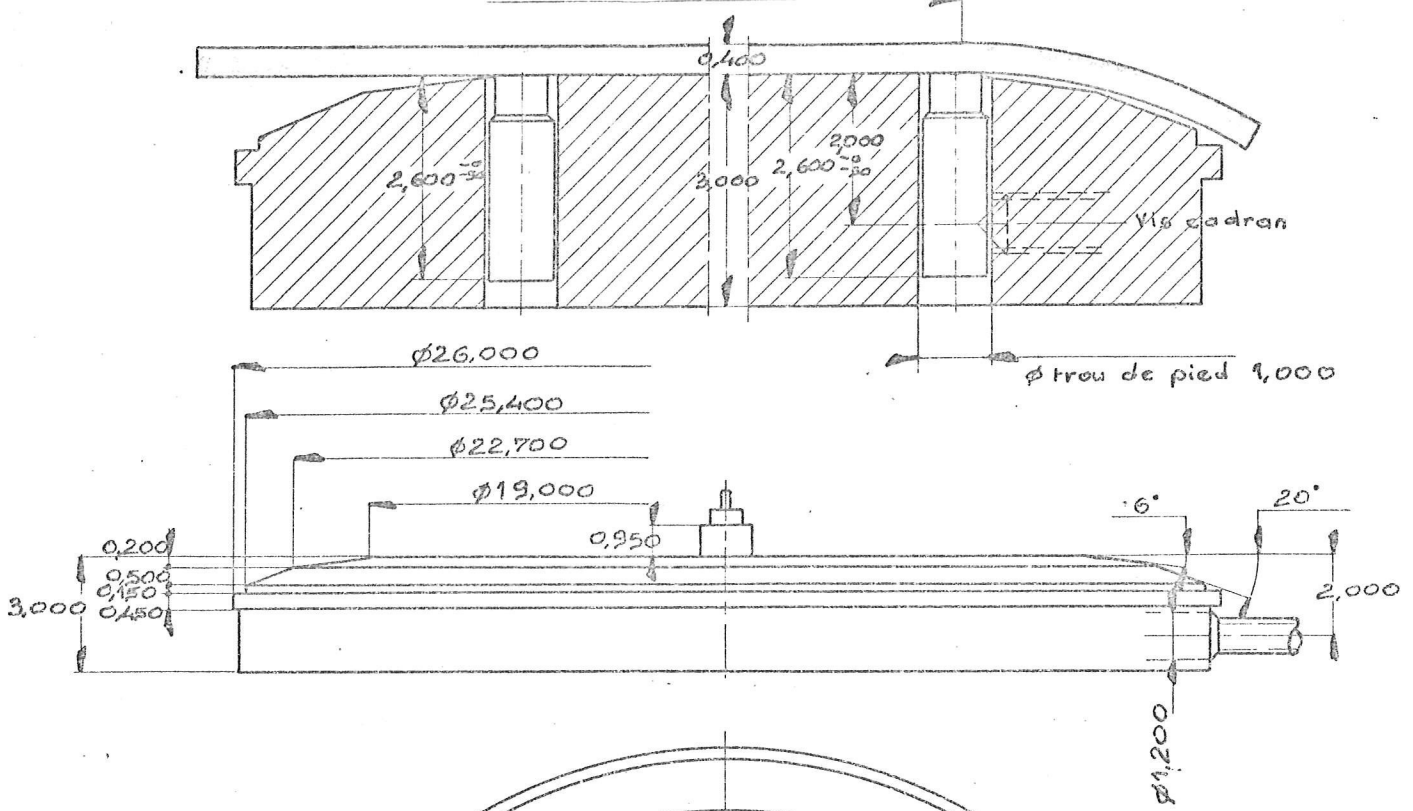

CAL 140. 11 1/2

CAGE POUR CADRAN

FRANCE EBAUCHES  
Centre technique

Matière : \_\_\_\_\_ Traitement : \_\_\_\_\_

F					
E					
D					
C					
B					

Cotes en mm. tolérances en microns  
Cotes sans tolérance :  
le : 9/9/69  
par : HM  
échelle :  
visa :

CAL 11 1/2 140  
140-21

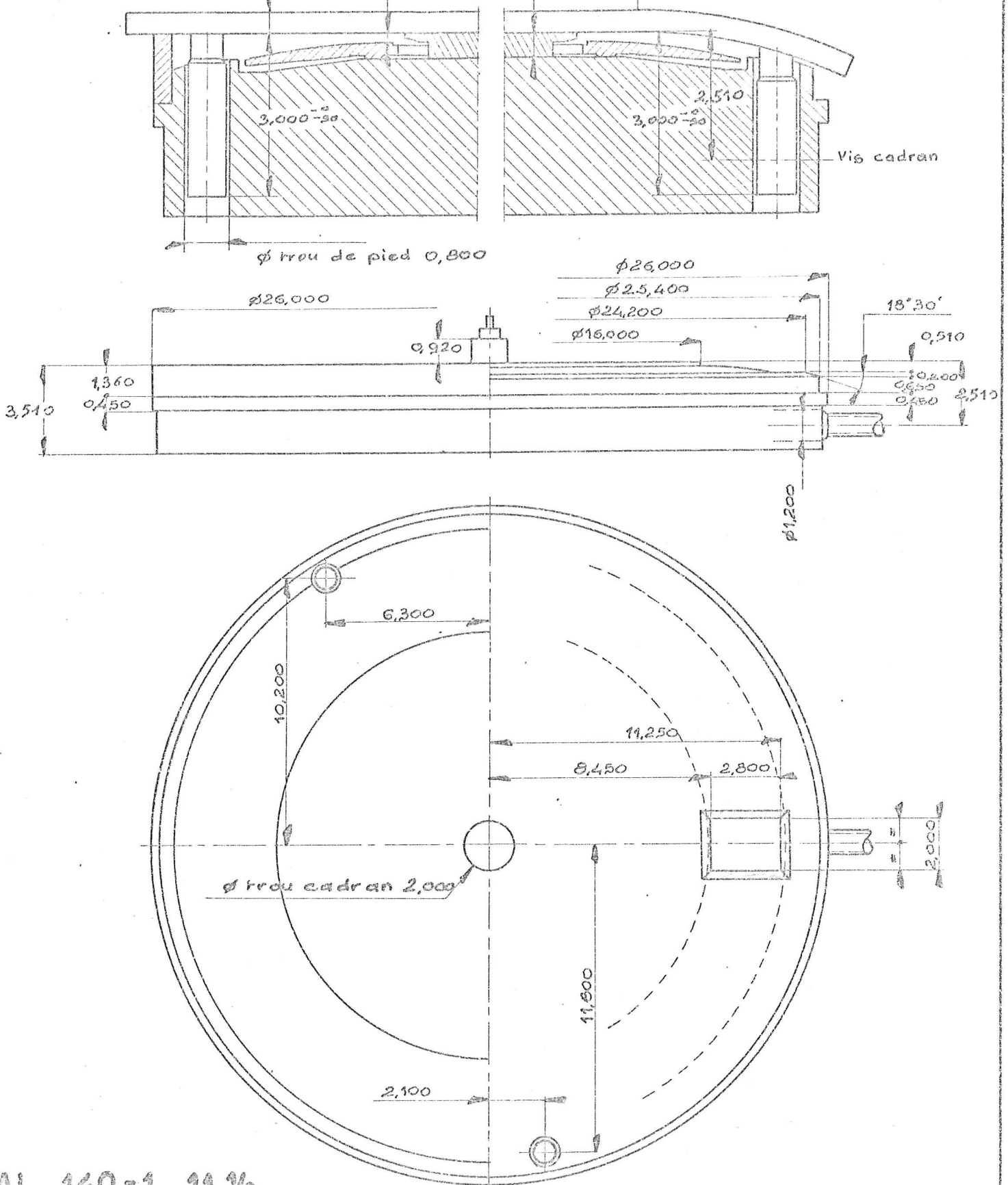

CAL 140-1 11 1/2

CAGE POUR CADRAN

FRANCE EBAUCHES

Centre technique

Matière : .....

Traitement : .....

F			
E			
D			
C			
B	9.7.70	Modification de cotes	

Cotes en mm. tolérances en microns

Cotes sans tolérance :

le : 9/9/69.

par : HW

échelle :

vis :

CAL 11 1/2 1401

1101-22

B

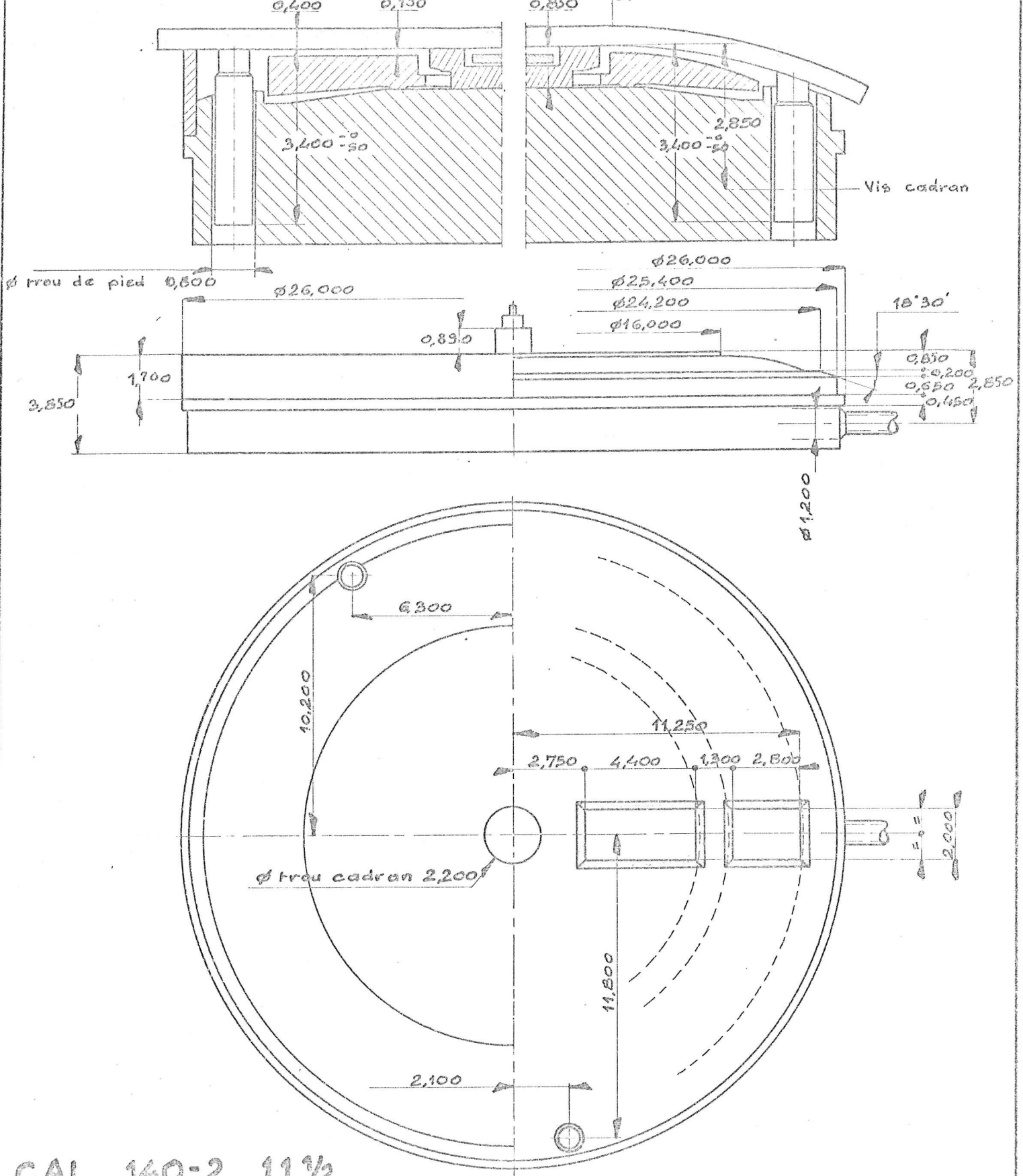

CAL 140-2 11½

CAGE POUR CADRAN Guichets séparés

FRANCE EBAUCHES  
Centre technique

Matière :

Traitement :

F	E	D	C	B
				9.7.70
Modification de cotes				

Cotes en mm. tolérances en microns

Cotes sans tolérance :

le :

par :

9/9/69

LM

échelle :

visa :

CAL 11½ 140-2

140-2-23

B

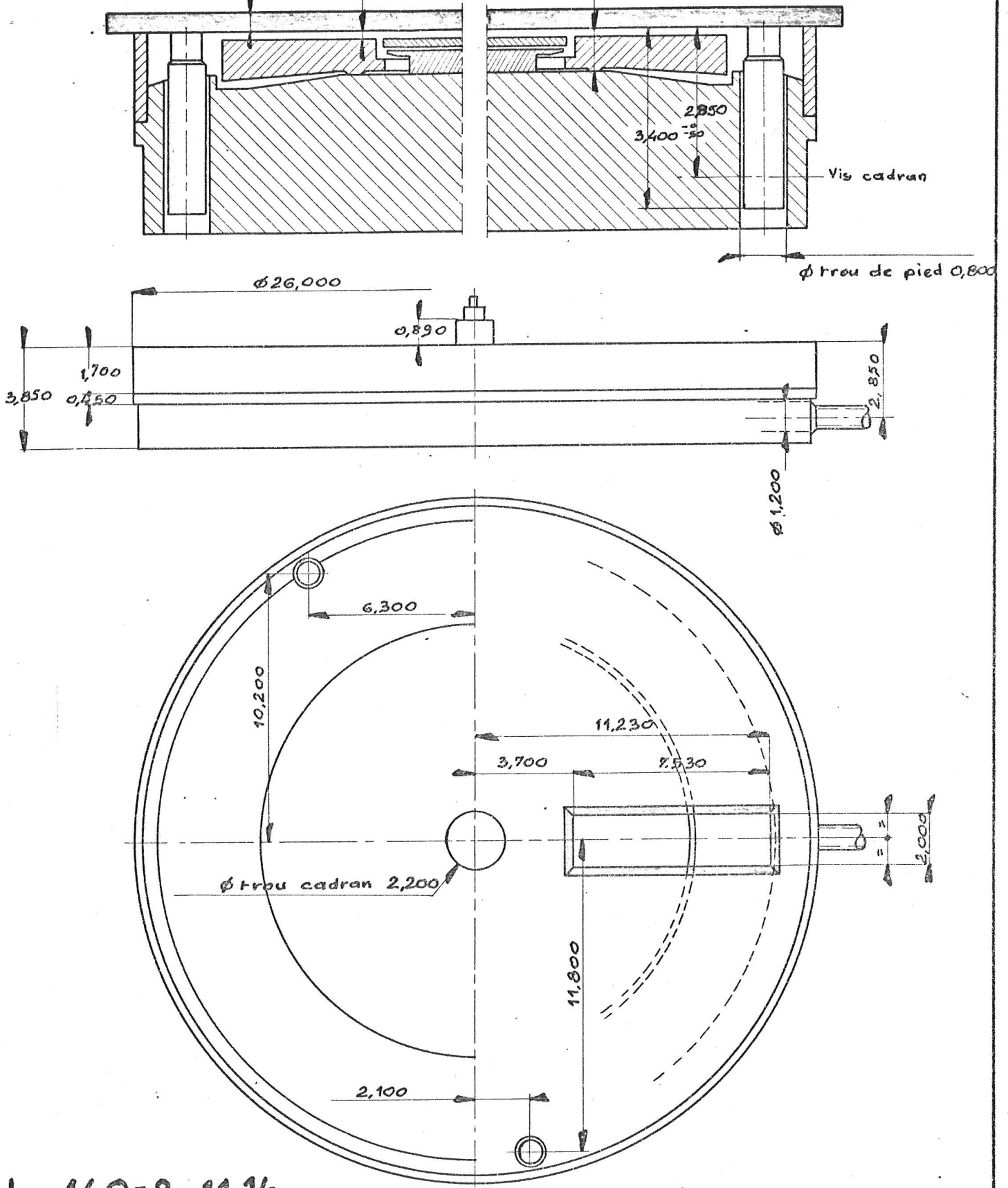

CAL 140-2 11 1/2

CAGE POUR CADRAN Guichet commun

FRANCE EBAUCHES  
Centre technique

Matière : .....

Traitement : .....

F	E	D	C	B
				3.7.70
				Modification de cotes

Cotes en mm. tolérances en microns	
Cotes sans tolérance :	
le :	par :
9/9/69	HM
échelle :	visa :

CAL 11 1/2 1402

140-2-24

B

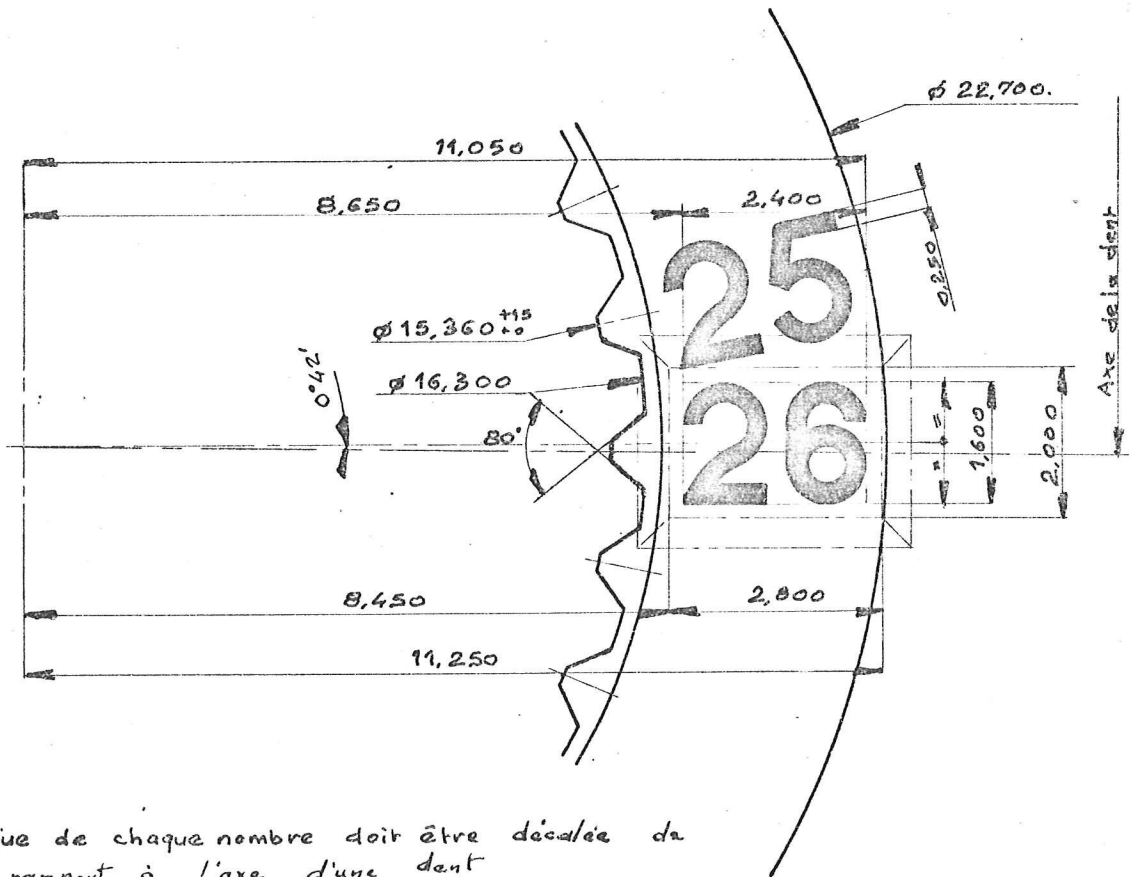
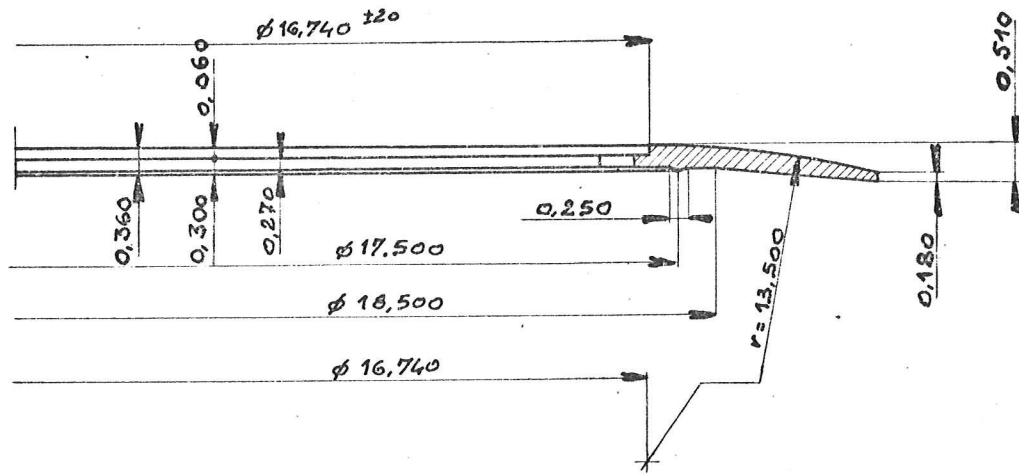

Nota: La décalque de chaque nombre doit être décalée de  $0^{\circ}42'$  par rapport à l'axe d'une dent  
 Décalque identique à celle du CAL 233-69

CAL 140-1 11 1/2

INDICATEUR DE QUANTIEME . Décalque

Guichet 3H

FRANCE EBAUCHES

Centre technique

F	E	D	C	B	Cotes en mm. tolérances en microns		CAL 11 1/2 140-1
					Cotes sans tolérance :		
					le :	par :	
Jun 70	Mod. position décalque et cotes épaisseur cadran	MB	11/6/69	LM			
Mars 70	Nsd rayon de courbure une 12,500. ep. bnc. 0,210 et ep. bnc. 0,150 hauteur cuben. 0,210				échelle :	visa :	

Disque pour cadran plat

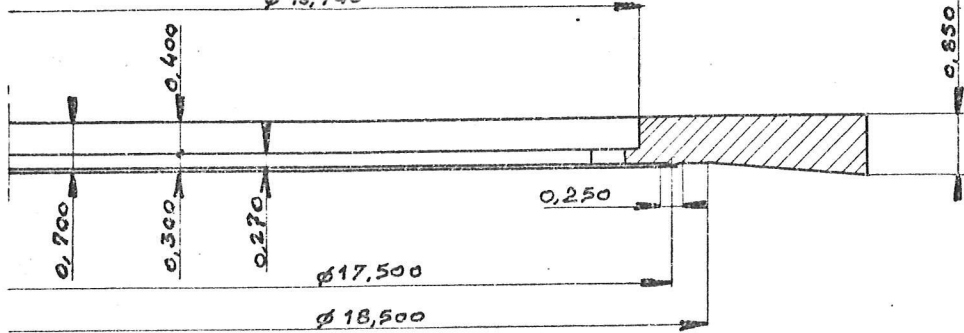

Disque pour cadran galbé

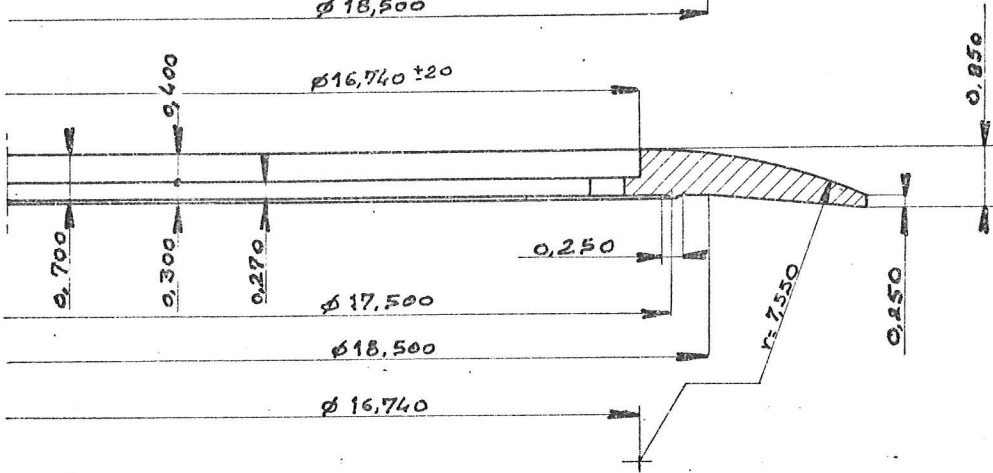

Guichets séparés

Guichet commun

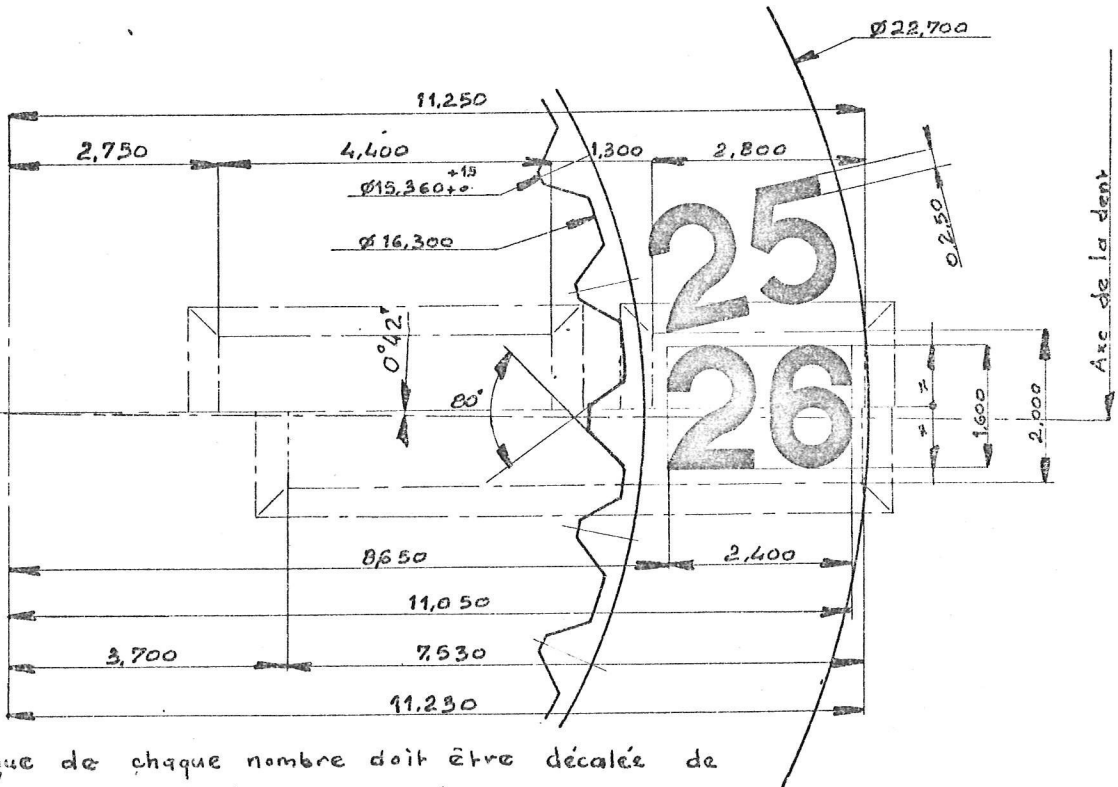

Nota: la décalque de chaque nombre doit être décalée de 0°42' par rapport à l'axe d'une dent.  
Même décalque que pour CAL 233-70.

CAL 140-2 11 1/2

INDICATEUR DE QUANTIEME . Décalque

Guichet 3H Guichets séparés et guichet commun

FRANCE ERAUCHES

Centre technique

F			Cotes en mm. tolérances en microns
E			Cotes sans tolérance :
D			la : par :
C			12/6/69 LM
B	Juin 70	Mod. position décalque et cotes épaisseur cadran M3	échelle : visa :

CAL 11 1/2 140-2

140-2-10

B



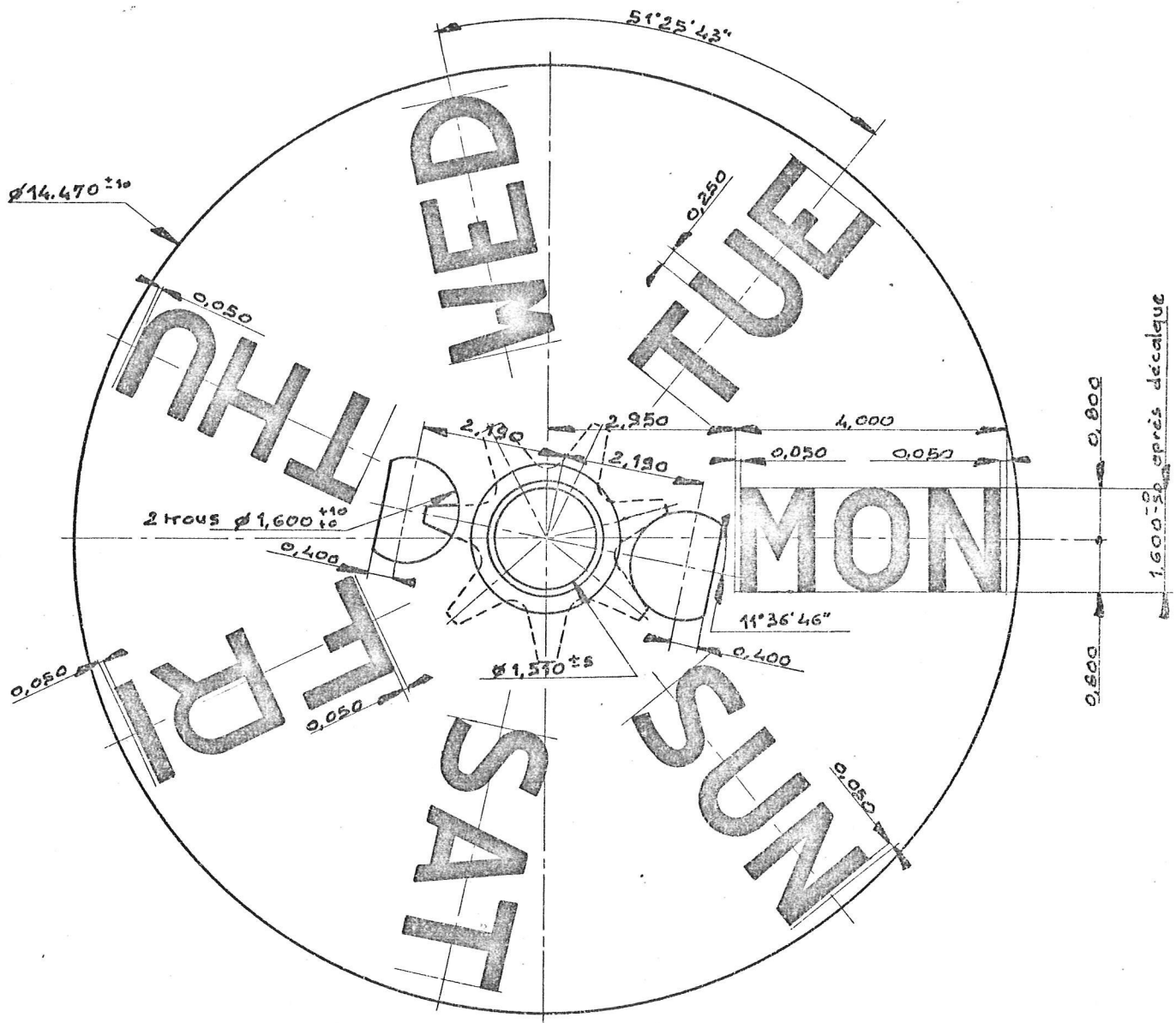

Nota: la décalque doit être décalée de  $11^\circ 36' 46''$  par rapport à l'axe des trous

CAL 140-2 11½

DISQUE DES JOURS Anglais

FRANCE EBAUCHES  
Centre technique

Matière : \_\_\_\_\_ Traitement : \_\_\_\_\_

F					
E					
D					
C					
B					

Cotes en mm. tolérances en microns  
Cotes sans tolérance :

le :	par :
2.5/9/69	M
échelle :	visa :

CAL 11½ 140-2

142-2606-09