

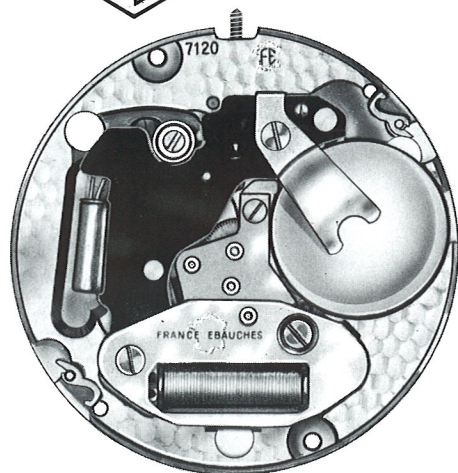

FRANCE ÉBAUCHES



7224

DUAL TIME

7234

11 1/2''' ∅ 25,6 mm

H = 3,48 mm

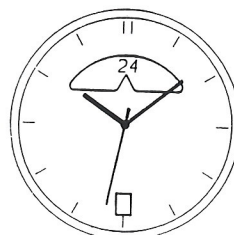

PAR DISQUE
BY DISK
DURCH SCHEIBE
字盤顯示

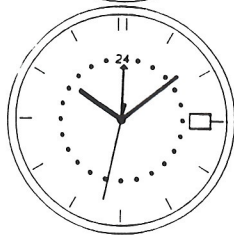

PAR AIGUILLE
BY HAND
DURCH ZEIGER
行針顯示

CARACTÉRISTIQUES TECHNIQUES	TECHNICAL DATA	TECHNISCHE DATEN	技术资料	mm 毫米
Cage Dimensions totales Dimensions encageage Hauteur du filet Hauteur sur tige Hauteur maximum	Frame Overall dimensions Casing dimensions Height at bead Height at stem Maximum height	Gestell Gesamte-Abmessungen Gehäuse-Passung Höhe am Wulst Höhe an der Welle Maximale Höhe	外壳 (框架) 总直径 外壳直径 表壳饰高度 把芯高度 最大高度	26.200 25.600 1.780 1.980 3.480
Tige de mise à l'heure Diamètre du filetage	Hand-setting stem Threading diameter	Stellwelle Gewindedurchmesser	机芯止动杆 把芯螺纹直径	0,900
Résonateur Fréquence	Resonator Frequency	Resonator Frequenz	谐振器 共振荡回声率	32.768 Hz
Moteur Nombre d'impulsions par minute	Motor Number of impulses p/minute	Motor Impulszahlh p/Minute	电动机 驱脉冲 次/分	60
Trimmer Exécution : 1 rubis	Trimmer Version : 1 jewel	Trimmer Ausführung : 1 Stein	调整片 型式: 1 钻 (宝石)	

Fournitures particulières		Specials parts		Sonderteile		专用零件	
7224 - 7234							
1002007 13101 30027 31083 31046 31062	100 2740 277 242 255 258	Platine Plaque de maintien du mécanisme de calendrier Roue de seconde Chaussée avec entraîneur Roue des heures Roue entraîneuse de roue des heures	Main plate Calendar mechanism maintaining plate Second wheel Cannon pinion with driver Hour wheel Hour wheel driving wheel	Werkplatte Halteplatte für Kalendermechanismus Sekundenrad Minutenrohr mit Mitnehmer Stundenrad Mitnehmerrad für Stundenrad	主夹板 周历机构盖板 二轮 带动齿轮 分轮部份 时轴转轴		
7224							
91400	9600/I	Indicateur des heures	Hour indicator	Stundenanzeiger	小时显示器		
7234							
31047 61241	251 499	Roue des heures 24 h Ressort-friction de roue des heures	Hour wheel 24 h Hour wheel friction spring	Stundenrad 24 St Frikionsfeder für Stundenrad	時計輪盤 (二十四小時) 時輪磨擦彈簧		
Autres pièces : voir document 7229			Other parts : See documentation for 7229		Andere Teile : Siehe Dokumentation für 7229		其餘部件， 詳見 7229 號文件

FRANCE ÉBAUCHES : 4, chemin du Fort de Bregille - B.P. 157 - 25014 BESANÇON CEDEX - FRANCE
Téléphone : 81.80.13.11 - Télex : 360 100 F - Téléfax : 81.80.34.21

H.G. BRUNNER Limited C/O L.D.J. (SCIENTIFIC) LTD

Post office Chambers 5a north street
Leatherhead Surrey
ENGLAND KT 22 7AX

HANS LEITZ

Rennfeldstrasse 31
D - 7530 Pforzheim - Germany
Téléphone : 07231/25739 - Télex 783 679

ASIANHOR

Singga Commercial Building
16th floor - 148 Connaught Road West HONG KONG
Téléphone : 5-464 881 - Telex : 73968
Telefax : 5-477 762

COMEXHOR - FEBE SUISSE

34, rue Alexis-Marie Piaget
CH - 2300 La Chaux-de-Fonds - Suisse
Téléphone : 039.28.63.36
Telefax : 039.28.63.40



CADRAN - DIAL - ZIFFERBLATT - 錶盤

7224

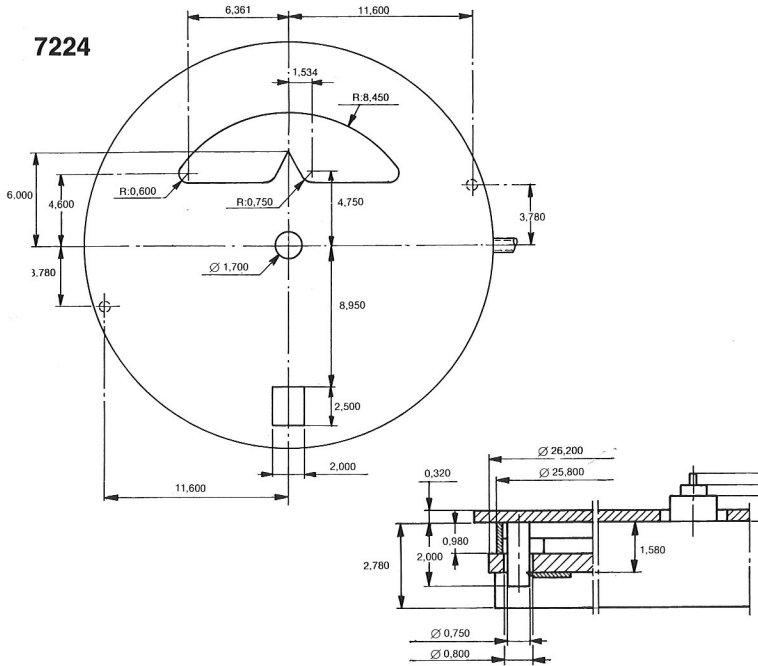

7234

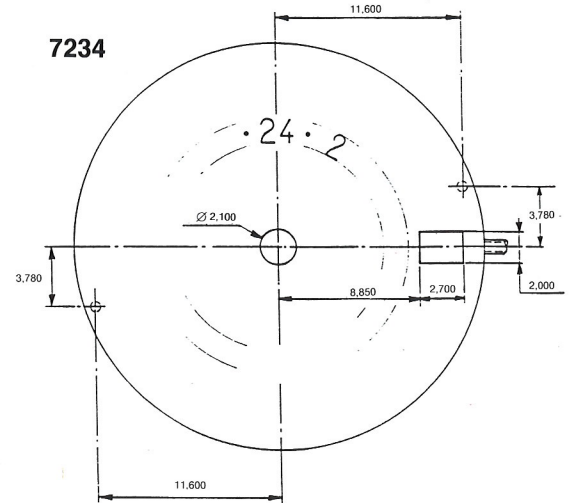

AIGUILLAGE - HANDFITTING - ZEIGERSETZEN - 錶針裝配

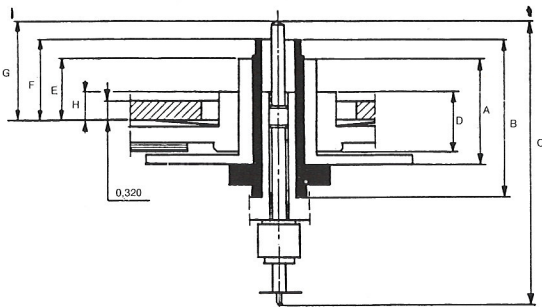

N°	Cal.	A	B	C	D	E	F	G	H
1	7224	1,470	2,280	4,340		0,670	0,970	1,290	
1	7234	1,720	2,530	4,590	1,040	0,920	1,220	1,540	0,420

Cadran d'épaisseur Zifferblattdicke
Dial thickness 錶盤厚度 = H 0,320

• Exécution
1 Normale

• Exécution
1 Normal

• Ausführung
1 Normal

* 型式 1. 正常

Roue des heures
Hour wheel
Stundenrad
時輪

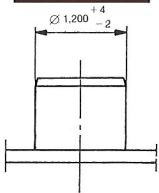

Chaussée
Cannon pinion
Minutenrohr
分輪

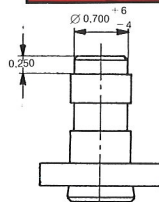

Seconde
Second
Sekunde
秒

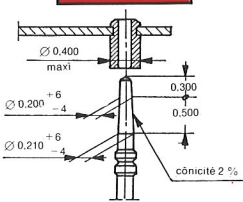

7234
Roue des heures 24 h
Hour wheel 24 h
Stundenrad 24 St
時針輪 (24小時)

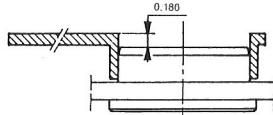
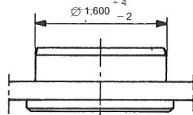

AIGUILLES
HANDS

ZEIGER
指針

7224 - 7234

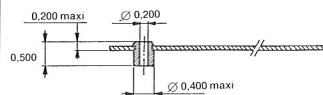

7224 - 7234

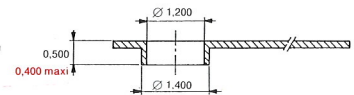

7224 - 7234

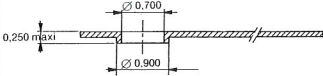

7234

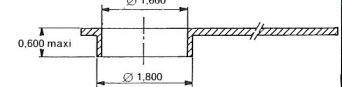

BOÎTES - CASING - EINSCHALEN - 錶殼

Voir documentation 7229
See documentation for 7229
Siehe Dokumentation für 7229
詳見 7229 號文件

Pile
Batterie
Battery
電池

UCAR 371
RW 315
VARTA 537
RENATA 371
SR 920 SW
I.E.C. SR 60

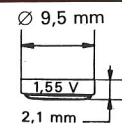

CONTRÔLES - TESTS KONTROLLE

檢驗

Voir documentation 7229
See documentation for 7229
Siehe Dokumentation für 7229
詳見 7229 號文件